

# Installation Note

---

## Extended Frequency Range Upgrade Kit

**Upgrade Kit Number: N5230-60108**

**For N5230A Standard Test Set, 20 GHz, 2-Port PNA-L**



**Agilent Part Number: N5230-90010**

**Printed in USA January 2005**

Supersedes all previous printings.

© Agilent Technologies, Inc. 2004, 2005

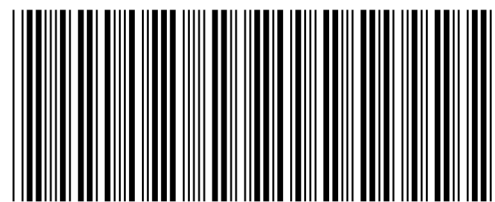

N5230-90010

---

## WARRANTY STATEMENT

THE MATERIAL CONTAINED IN THIS DOCUMENT IS PROVIDED “AS IS,” AND IS SUBJECT TO BEING CHANGED, WITHOUT NOTICE, IN FUTURE EDITIONS. FURTHER, TO THE MAXIMUM EXTENT PERMITTED BY APPLICABLE LAW, AGILENT DISCLAIMS ALL WARRANTIES, EITHER EXPRESS OR IMPLIED WITH REGARD TO THIS MANUAL AND ANY INFORMATION CONTAINED HEREIN, INCLUDING BUT NOT LIMITED TO THE IMPLIED WARRANTIES OF MERCHANTABILITY AND FITNESS FOR A PARTICULAR PURPOSE. AGILENT SHALL NOT BE LIABLE FOR ERRORS OR FOR INCIDENTAL OR CONSEQUENTIAL DAMAGES IN CONNECTION WITH THE FURNISHING, USE, OR PERFORMANCE OF THIS DOCUMENT OR ANY INFORMATION CONTAINED HEREIN. SHOULD AGILENT AND THE USER HAVE A SEPARATE WRITTEN AGREEMENT WITH WARRANTY TERMS COVERING THE MATERIAL IN THIS DOCUMENT THAT CONFLICT WITH THESE TERMS, THE WARRANTY TERMS IN THE SEPARATE AGREEMENT WILL CONTROL.

---

## DFARS/Restricted Rights Notice

If software is for use in the performance of a U.S. Government prime contract or subcontract, Software is delivered and licensed as “Commercial computer software” as defined in DFAR 252.227-7014 (June 1995), or as a “commercial item” as defined in FAR 2.101(a) or as “Restricted computer software” as defined in FAR 52.227-19 (June 1987) or any equivalent agency regulation or contract clause. Use, duplication or disclosure of Software is subject to Agilent Technologies’ standard commercial license terms, and non-DOD Departments and Agencies of the U.S. Government will receive no greater than Restricted Rights as defined in FAR 52.227-19(c)(1-2) (June 1987). U.S. Government users will receive no greater than Limited Rights as defined in FAR 52.227-14 (June 1987) or DFAR 252.227-7015 (b)(2) (November 1995), as applicable in any technical data.

---

## Safety Notes

The following safety notes are used throughout this document. Familiarize yourself with each of these notes and its meaning before performing any of the procedures in this document.

---

<b>WARNING</b>	<b>Warning denotes a hazard. It calls attention to a procedure which, if not correctly performed or adhered to, could result in injury or loss of life. Do not proceed beyond a warning note until the indicated conditions are fully understood and met.</b>
----------------	---

---

<b>CAUTION</b>	Caution denotes a hazard. It calls attention to a procedure that, if not correctly performed or adhered to, could result in damage to or destruction of the instrument. Do not proceed beyond a caution sign until the indicated conditions are fully understood and met.
----------------	---

---

## Getting Assistance from Agilent

By internet, phone, or fax, get assistance with all your test and measurement needs.

This information supersedes all prior HP contact information.			
<b>Online assistance:</b> <a href="http://www.agilent.com/find/assist">www.agilent.com/find/assist</a>			
<b>Americas</b>			
<b>Brazil</b> (tel) (+55) 11 3351 7012 (fax) (+55) 11 3351 7024	<b>Canada</b> (tel) +1 877 894 4414 (fax) +1 303 662 3369	<b>Mexico</b> (tel) 1 800 254 2440 (fax) 1 800 254 4222	<b>United States</b> (tel) 800 829 4444 (alt) (+1) 303 662 3998 (fax) 800 829 4433
<b>Asia Pacific and Japan</b>			
<b>Australia</b> (tel) 1 800 225 574 (fax) 1 800 681 776 (fax) 1 800 225 539	<b>China</b> (tel) 800 810 0508 (alt) 800 810 0510 (fax) 800 810 0507 (fax) 800 810 0362	<b>Hong Kong</b> (tel) 800 933 229 (fax) 800 900 701	<b>India</b> (tel) 1600 112 626 (fax) 1600 112 727 (fax) 1600 113 040
<b>Japan (Bench)</b> (tel) 0120 32 0119 (alt) (+81) 426 56 7799 (fax) 0120 01 2144	<b>Japan (On-Site)</b> (tel) 0120 802 363 (alt) (+81) 426 56 7498 (fax) (+81) 426 60 8953	<b>Singapore</b> (tel) 1 800 275 0880 (fax) (+65) 6755 1235 (fax) (+65) 6755 1214	<b>South Korea</b> (tel) 080 778 0011 (fax) 080 778 0013
<b>Taiwan</b> (tel) 0800 047 669 (fax) 0800 047 667 (fax) 886 3492 0779	<b>Thailand</b> (tel) 1 800 2758 5822 (alt) (+66) 2267 5913 (fax) 1 800 656 336	<b>Malaysia</b> (tel) 1800 880 399 (fax) 1800 801 054	
<b>Europe</b>			
<b>Austria</b> (tel) 0820 87 44 11* (fax) 0820 87 44 22	<b>Belgium</b> (tel) (+32) (0)2 404 9340 (alt) (+32) (0)2 404 9000 (fax) (+32) (0)2 404 9395	<b>Denmark</b> (tel) (+45) 7013 1515 (alt) (+45) 7013 7313 (fax) (+45) 7013 1555	<b>Finland</b> (tel) (+358) 10 855 2100 (fax) (+358) (0) 10 855 2923
<b>France</b> (tel) 0825 010 700* (alt) (+33) (0)1 6453 5623 (fax) 0825 010 701*	<b>Germany</b> (tel) 01805 24 6333* (alt) 01805 24 6330* (fax) 01805 24 6336*	<b>Ireland</b> (tel) (+353) (0)1 890 924 204 (alt) (+353) (0)1 890 924 206 (fax) (+353) (0)1 890 924 024	<b>Israel</b> (tel) (+972) 3 9288 500 (fax) (+972) 3 9288 501
<b>Italy</b> (tel) (+39) (0)2 9260 8484 (fax) (+39) (0)2 9544 1175	<b>Luxemburg</b> (tel) (+32) (0)2 404 9340 (alt) (+32) (0)2 404 9000 (fax) (+32) (0)2 404 9395	<b>Netherlands</b> (tel) (+31) (0)20 547 2111 (alt) (+31) (0)20 547 2000 (fax) (+31) (0)20 547 2190	<b>Russia</b> (tel) (+7) 095 797 3963 (alt) (+7) 095 797 3900 (fax) (+7) 095 797 3901
<b>Spain</b> (tel) (+34) 91 631 3300 (alt) (+34) 91 631 3000 (fax) (+34) 91 631 3301	<b>Sweden</b> (tel) 0200 88 22 55* (alt) (+46) (0)8 5064 8686 (fax) 020 120 2266*	<b>Switzerland (French)</b> (tel) 0800 80 5353 opt. 2* (alt) (+33) (0)1 6453 5623 (fax) (+41) (0)22 567 5313	<b>Switzerland (German)</b> (tel) 0800 80 5353 opt. 1* (alt) (+49) (0)7031 464 6333 (fax) (+41) (0)1 272 7373
<b>Switzerland (Italian)</b> (tel) 0800 80 5353 opt. 3* (alt) (+39) (0)2 9260 8484 (fax) (+41) (0)22 567 5314	<b>United Kingdom</b> (tel) (+44) (0)7004 666666 (alt) (+44) (0)7004 123123 (fax) (+44) (0)7004 444555		
(tel) = primary telephone number; (alt) = alternate telephone number; (fax) = FAX number; * = in country number 11/16/04			

---

## Description of the Upgrade

This upgrade extends the upper frequency limit of your 20 GHz standard test set analyzer to 40 GHz. This is done by installing Option F40.

Option F40 provides the necessary 40 GHz components and cabling to allow your analyzer to measure signals up to 40 GHz.

---

## About Installing the Upgrade

Products affected . . . . .	N5230A; standard test set, 20 GHz, 2-port
Installation to be performed by . . . . .	Agilent service center or personnel qualified by Agilent
Estimated installation time . . . . .	2.0 hours
Estimated adjustment time . . . . .	0.5 hours
Estimated full instrument calibration time . . . .	4.5 hours

---

## Items Included in the Upgrade Kit

Check the contents of your kit against the following list. If any part is missing or damaged, contact Agilent Technologies. Refer to [“Getting Assistance from Agilent”](#) on page 3.

**Table 1** Contents of Upgrade Kit N5230-60108

Ref Desig.	Description	Qty	Part Number
	Installation note (this document)	1	N5230-90010
A18	Modulator/amplifier 26.5 (MA 26.5)	1	5087-7280
A19	Modulator/amplifier/switch/splitter 50 (MASS 50)	1	5087-7278
A20	Mixer brick 50	1	5087-7279
A21, A22	Test port coupler, 50 GHz	2	5086-7518
	Machine screw, M3.0 x 10 pan head (for attaching A18 MA 26.5)	3	0515-0374
	Rubber bumper (for A21 and A22 test port couplers)	2	0403-0285
	4-dB pad	1	0955-0583
	Test set deck front panel, 50 GHz	1	E8364-00014
	Cable tie (to secure cables W47 and W51 to the side frame)	3	1400-0249
	40 GHz nameplate	1	N5230-80003
	Ribbon cable, A18 MA 26.5 to A16 test set motherboard	1	N5230-60014
W3	RF cable, A6 multiplier board to A20 mixer brick	1	N5230-20043
W6	RF cable, A8 multiplier board to A18 MA 26.5	1	N5230-20044
W7	RF cable, A18 MA 26.5 to A19 MASS 50	1	N5230-20033
W8	RF cable, A19 MASS 50 to A21 test port 1 coupler	1	N5230-20027
W9	RF cable, A19 MASS 50 to A22 test port 2 coupler	1	N5230-20026
W10	RF cable, A19 MASS 50 to A20 mixer brick (R1)	1	N5230-20028
W11	RF cable, A19 MASS 50 to A20 mixer brick (R2)	1	N5230-20025
W12	RF cable, A21 test port 1 coupler to A20 mixer brick (A)	1	N5230-20029
W13	RF cable, A22 test port 2 coupler to A20 mixer brick (B)	1	N5230-20024

---

## Installation Procedure for the Upgrade

The network analyzer must be in proper working condition prior to installing this option. Any necessary repairs must be made before proceeding with this installation.

---

**WARNING**      **This installation requires the removal of the analyzer’s protective outer covers. The analyzer must be powered down and disconnected from the mains supply before performing this procedure.**

---

### Electrostatic Discharge Protection

Protection against electrostatic discharge (ESD) is essential while removing or connecting cables or assemblies within the network analyzer.

Static electricity can build up on your body and can easily damage sensitive internal circuit elements when discharged. Static discharges too small to be felt can cause permanent damage. To prevent damage to the instrument:

- *always* have a grounded, conductive table mat in front of your test equipment.
- *always* wear a grounded wrist strap, connected to a grounded conductive table mat, having a 1 M $\Omega$  resistor in series with it, when handling components and assemblies or when making connections.
- *always* wear a heel strap when working in an area with a conductive floor. If you are uncertain about the conductivity of your floor, wear a heel strap.
- *always* ground yourself before you clean, inspect, or make a connection to a static-sensitive device or test port. You can, for example, grasp the grounded outer shell of the test port or cable connector briefly.

Figure 1 shows a typical ESD protection setup using a grounded mat and wrist strap. Refer to “ESD Equipment and Supplies Required for the Installation” on page 7 for part numbers.

**Figure 1**    **ESD Protection Setup**

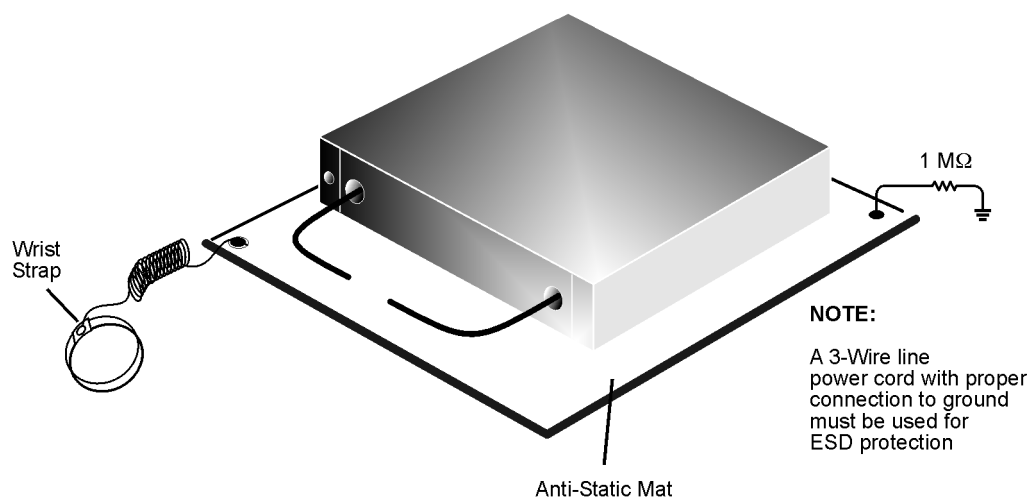

esd\_setup

## Tools Required for the Installation

Description	Agilent Part Number
T-10 TORX driver (set to 9 in-lbs)	N/A
T-20 TORX driver (set to 21 in-lbs)	N/A
5/16-inch torque wrench (set to 10 in-lbs)	N/A
1-inch torque wrench (set to 72 in-lbs)	N/A

## ESD Equipment and Supplies Required for the Installation

Description	Agilent Part Number
ESD grounding wrist strap	9300-1367
5-ft grounding cord for wrist strap	9300-0980
2 x 4 ft conductive table mat and 15-ft grounding wire	9300-0797
ESD heel strap (for use with conductive floors)	9300-1308

## Equipment Required for Post-Upgrade Adjustments

Equipment Type	Model or Part Number	Alternate Model or Part Number
Power meter	E4418B/E4419B	E4418A/E4419A
Power sensor, 2.4 mm	8487A	None
Adapter, 2.4 mm (f) to 2.4 mm (f)	11900B	85056-60007
RF cable, 2.4 mm (f) to 2.4 mm (f)	85133C	85133E

## **Overview of the Installation Procedure**

- Step 1. Remove the Outer and Inner Covers.
- Step 2. Remove the Front Panel Assembly.
- Step 3. Remove the 20 GHz Bottom Cables.
- Step 4. Remove the Test Set Deck Front Panel.
- Step 5. Remove the 20 GHz Top to Bottom Cables.
- Step 6. Remove the 20 GHz Components.
- Step 7. Install the 50 GHz Components.
- Step 8. Install the 50 GHz Top to Bottom Cables.
- Step 9. Install the New Test Set Deck Front Panel.
- Step 10. Install the 50 GHz Bottom Cables.
- Step 11. Replace the Nameplate.
- Step 12. Reinstall the Front Panel Assembly.
- Step 13. Reinstall the Inner and Outer Covers.
- Step 14. Enable Option F40.
- Step 15. Perform Post-Upgrade Adjustments.



## Step 1. Remove the Outer and Inner Covers

### Remove the Outer Cover

---

**CAUTION** This procedure is best performed with the analyzer resting on its front handles in the vertical position. *Do not place the analyzer on its front panel without the handles.* This will damage the front panel assemblies.

---

Refer to [Figure 2](#) for this procedure.

1. Disconnect the power cord (if it has not already been disconnected).
2. With a T-20 TORX driver, remove the strap handles (item ①) by loosening the screw (item ②) on each end of each handle.
3. With a T-20 TORX driver, remove the four rear panel feet (item ③) by removing the center screws (item ④).
4. Slide the four bottom feet (item ⑤) off the cover.
5. Slide the cover off of the frame.

**Figure 2 Outer Cover Removal**

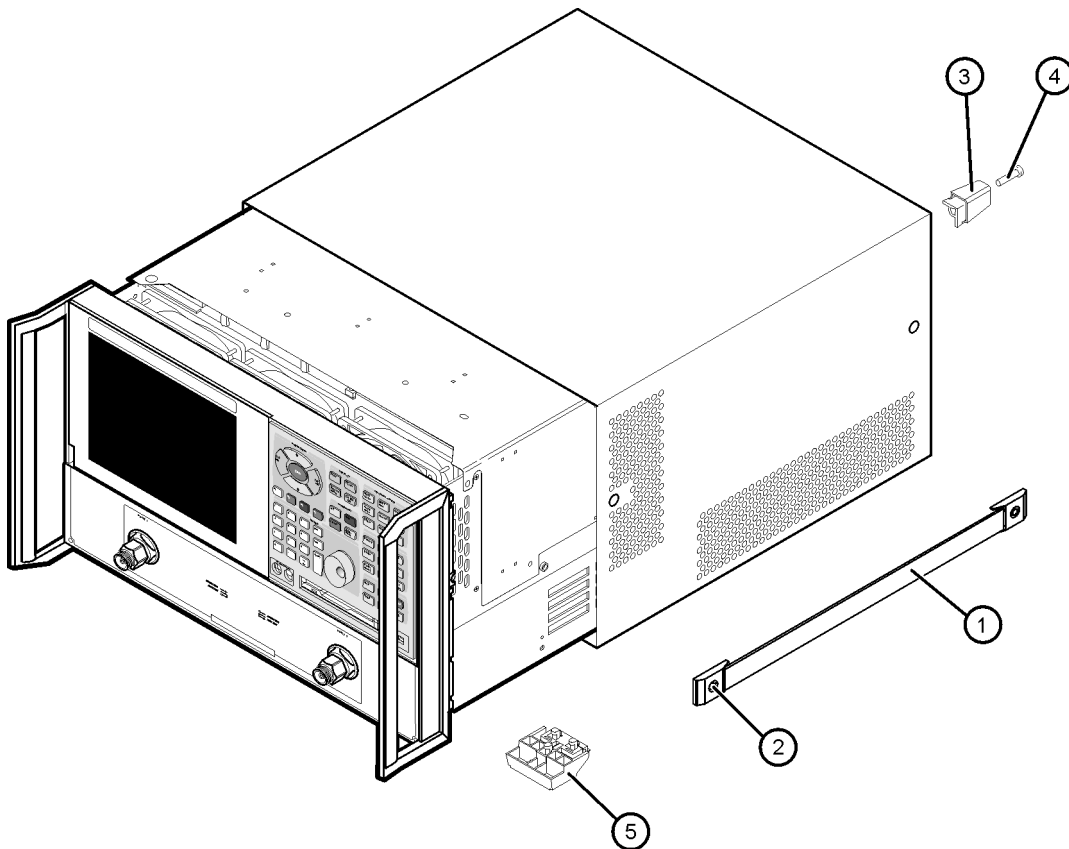

dt501a

## Remove the Inner Cover

1. Place the analyzer top-side up on a flat surface.
2. Using a T-10 TORX driver, remove the eleven screws (item ①).
3. Lift off the cover.

**Figure 3 Inner Cover Removal**

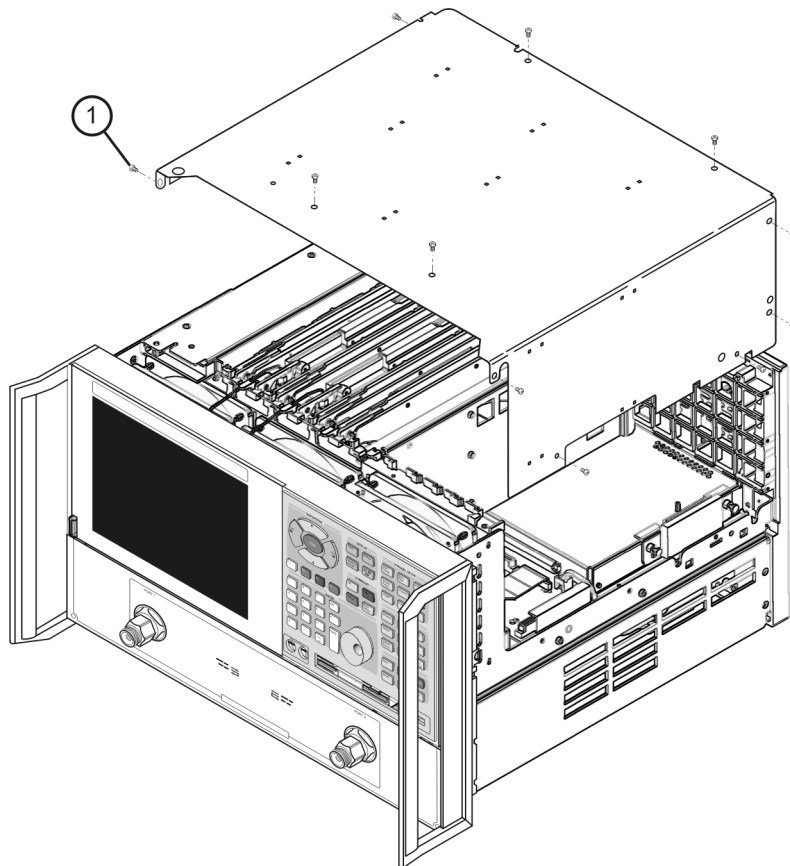

n5230\_010\_01

## Step 2. Remove the Front Panel Assembly

Refer to [Figure 4](#) for this procedure.

1. With a T-10 TORX driver, remove the eight screws (item ①) from the sides of the frame.

---

**CAUTION** Before removing the front panel from the analyzer, lift and support the front of the analyzer chassis.

---

2. Slide the front panel over the test port connectors.
3. Disconnect the front panel interface ribbon cable (item ②). The front panel is now free from the analyzer.

**Figure 4 Front Panel Assembly Removal**

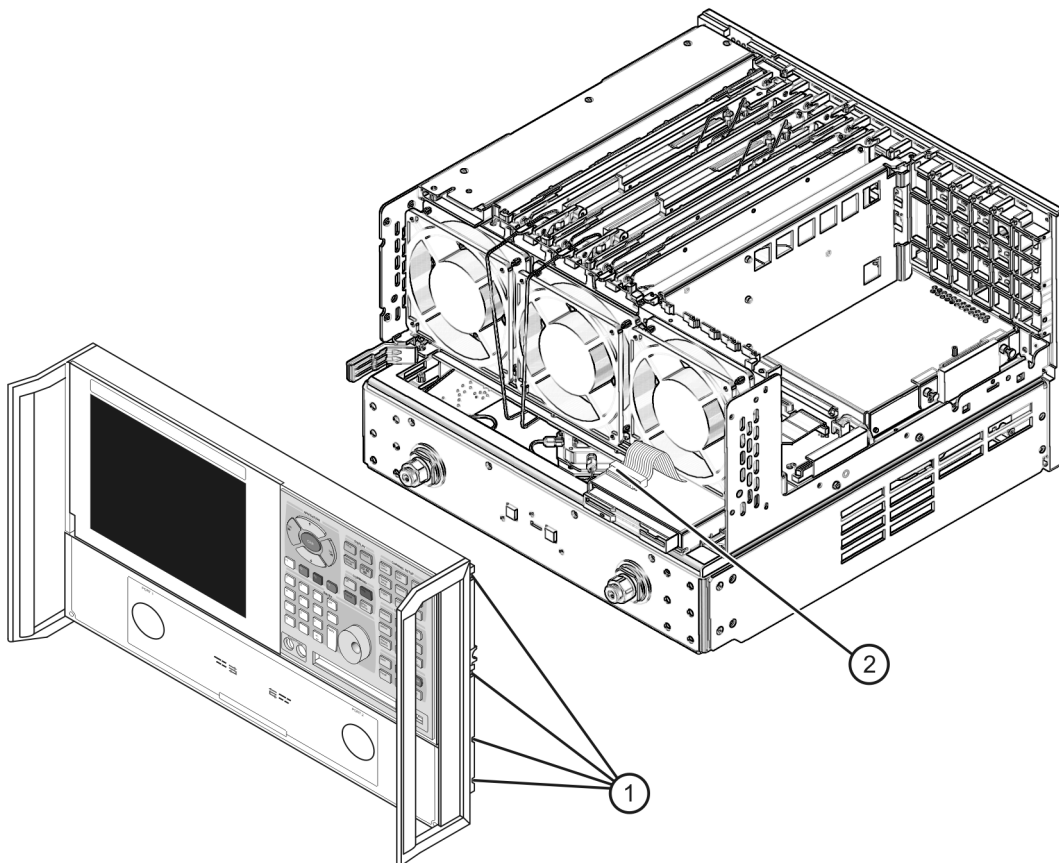

n5230\_010\_02

### Step 3. Remove the 20 GHz Bottom Cables

Refer to [Figure 5](#) for this procedure.

1. Place the analyzer bottom-side up on a flat surface.
2. Remove the following cables in the order listed:
  - W8 A17 MASS 26.5 to A21 test port 1 coupler
  - W10 A17 MASS 26.5 to A20 mixer brick (R1)
  - W12 A21 test port 1 coupler to A20 mixer brick (A)
  - W9 A17 MASS 26.5 to A22 test port 2 coupler
  - W11 A17 MASS 26.5 to A20 mixer brick (R2)
  - W13 A22 test port 2 coupler to A20 mixer brick (B)

**Figure 5 20 GHz Bottom Cables Removal**

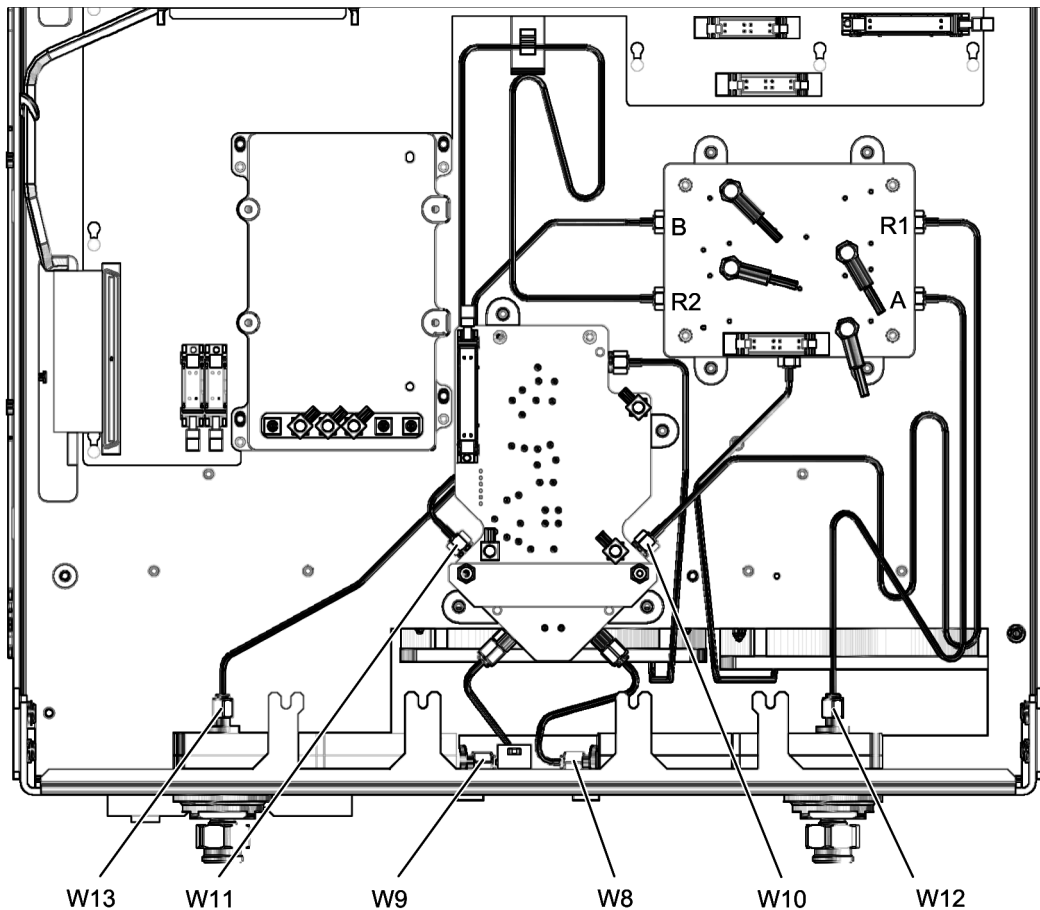

n5230\_010\_03

## Step 4. Remove the Test Set Deck Front Panel

Refer to [Figure 6](#) for this procedure.

1. Disconnect the wrapped wire cable (item ①) from the front-panel LED board.
2. Using a T-10 TORX driver, remove eight screws (items ① through ⑧) from the test set deck front panel, to release it.
3. Remove the test set deck front panel from the analyzer, with the LED board and both couplers attached.
4. Remove the LED board from the front panel by removing the three attachment screws. Retain the LED board and the screws for installation on the new front panel.
5. Using a 1-inch wrench, remove the flange nut (item ②) from each coupler. Retain the flange nuts for installation of the new couplers. Discard the front panel and the couplers.

**Figure 6 Test Set Deck Front Panel Removal**

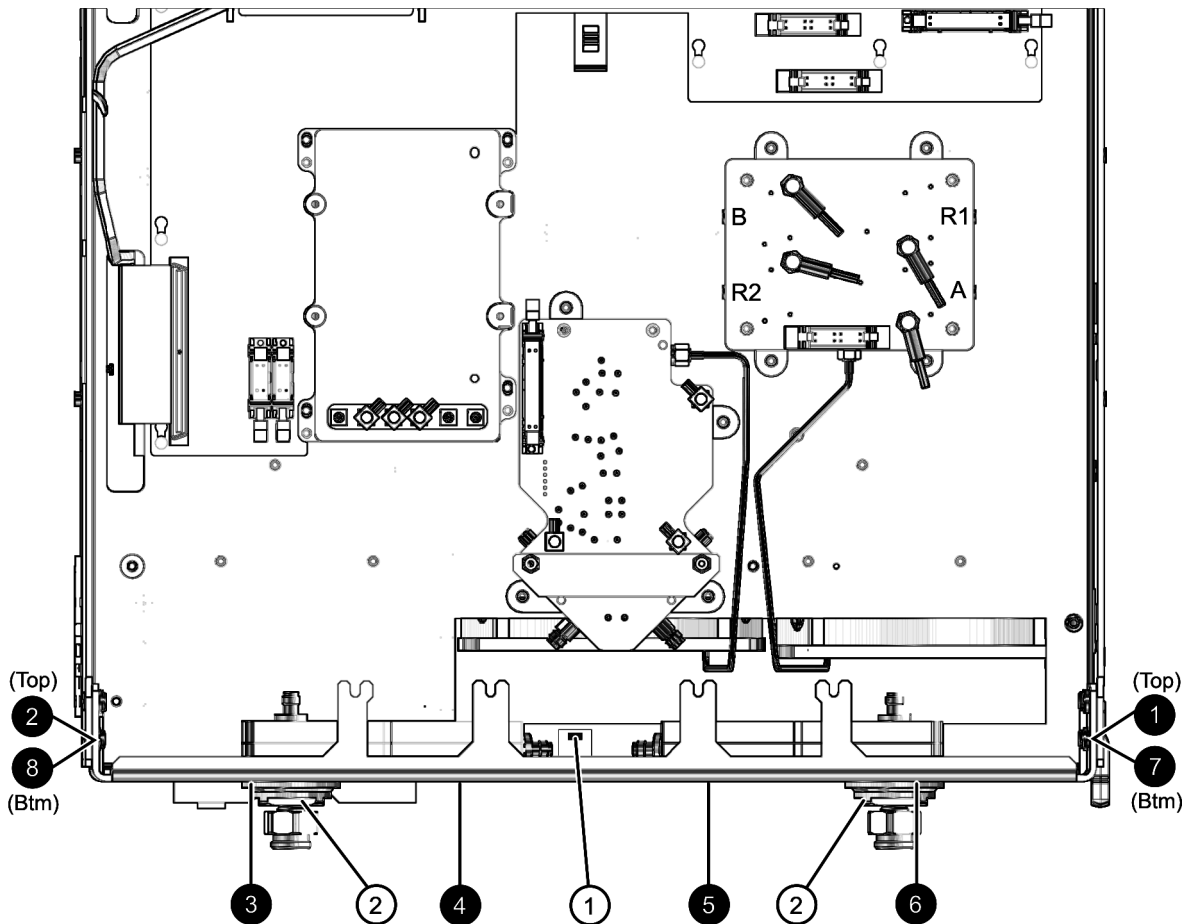

n5230\_010\_04

## Step 5. Remove the 20 GHz Top to Bottom Cables

1. Disconnect cables W3 and W6 at the locations shown in [Figure 7](#).
2. Place the analyzer on its side as shown in [Figure 8](#).
3. Disconnect cables W3 and W6 at the locations shown in [Figure 8](#) and remove the cables in the direction indicated. It may be necessary to guide the other end of the cables, on the bottom side of the analyzer, as they are being removed.

**Figure 7 20 GHz Top to Bottom Cables Removal, Bottom**

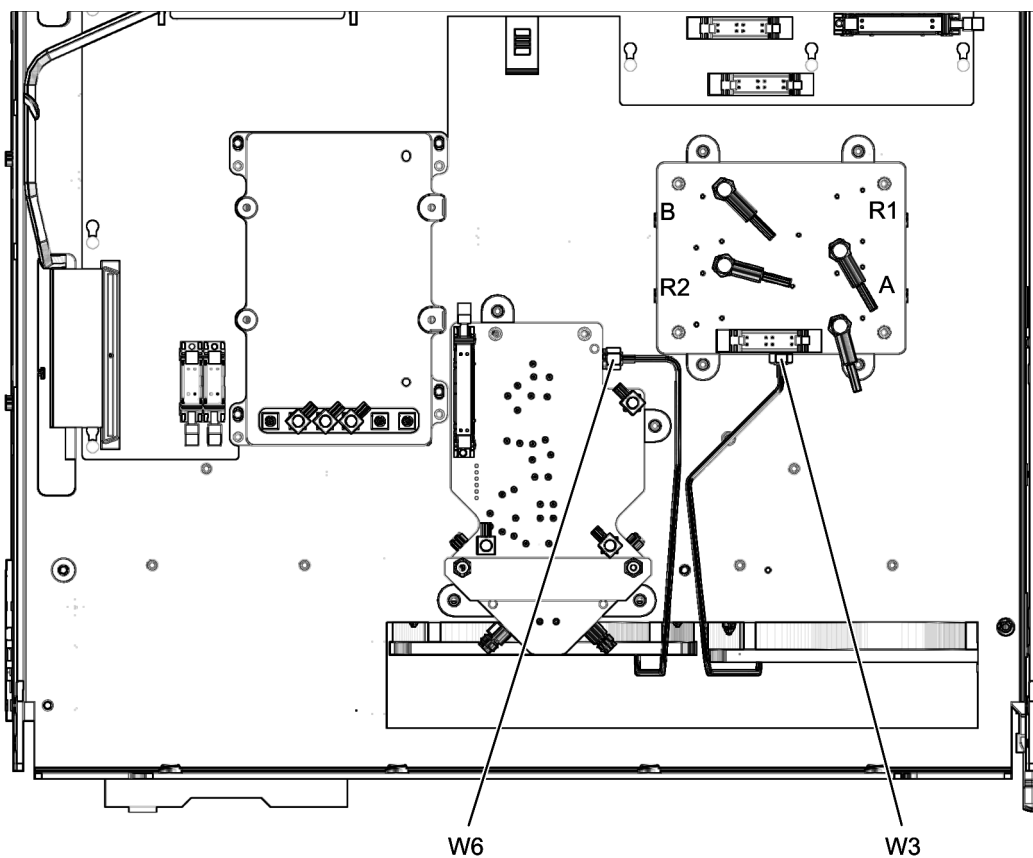

n5230\_010\_05

**Figure 8 20 GHz Top to Bottom Cables Removal, Top**

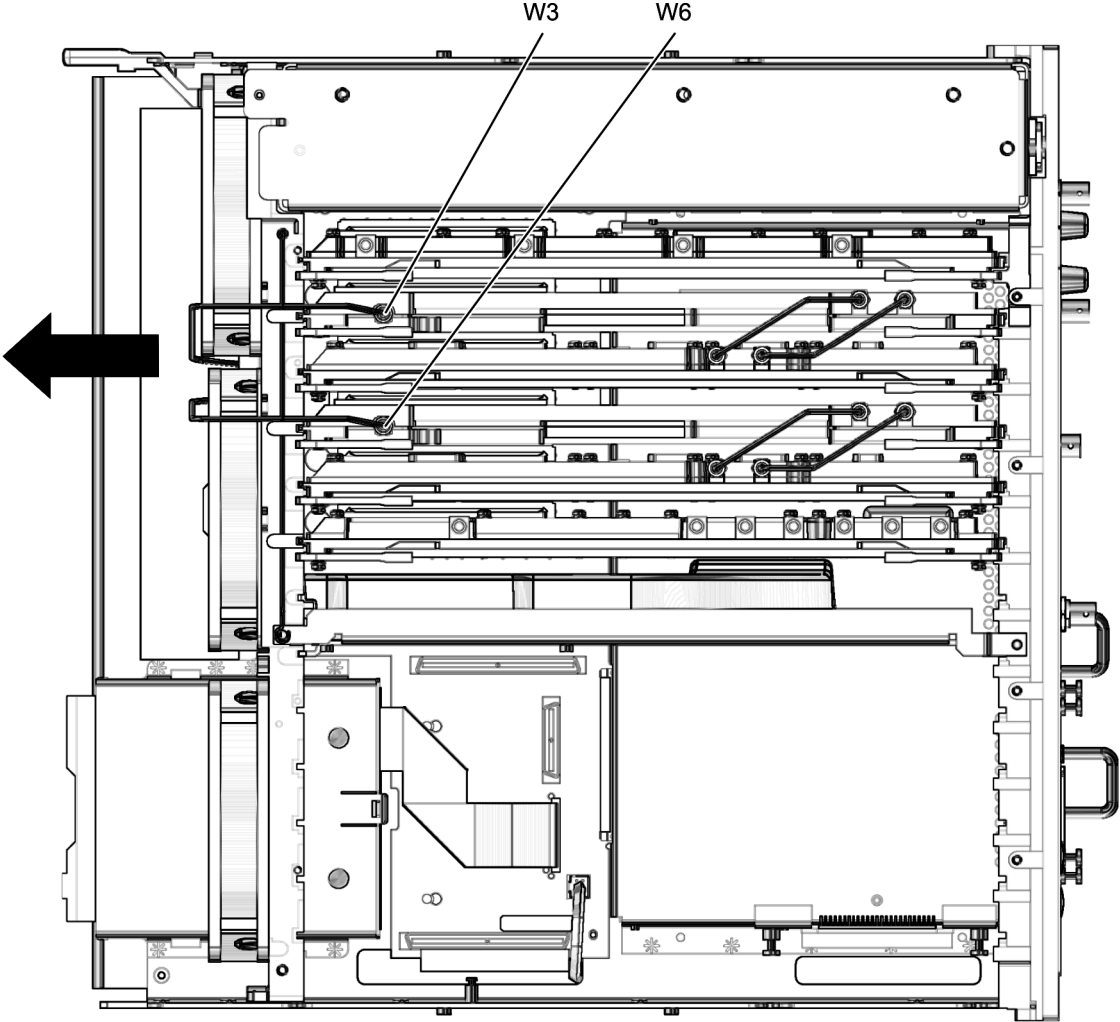

n5230\_010\_06

## Step 6. Remove the 20 GHz Components

Refer to [Figure 9](#) for this procedure.

1. Place the analyzer bottom-side up on a flat surface.

### Remove the A17 MASS 26.5

2. Disconnect the ribbon cable (item ①) from the MASS 26.5. Leave this ribbon cable attached to the A16 test set motherboard.
3. Disconnect the three flexible coaxial cables, W29–W31, from the MASS 26.5. Leave these cables connected at the other end.
4. Remove the MASS 26.5 by removing the four attachment screws (item ②). Retain the screws for installation of the A19 MASS 50.

### Remove the A20 Mixer Brick

5. Disconnect the ribbon cable (item ③) from the mixer brick. Leave this ribbon cable attached to the A16 test set motherboard.
6. Label, for re-connection later, the four flexible coaxial cables, W21–W24, that are connected to the mixer brick. It is necessary to label these cables because they connect to the A5 SPAM board on the top side of the analyzer and it is therefore difficult to trace their connection path and location. Disconnect these four cables from the mixer brick but leave them connected at the other end.
7. Remove the mixer brick by removing the four attachment screws (item ④). Retain the screws for installation of the A20 50 GHz mixer brick.



**Figure 9 20 GHz Components Removal**

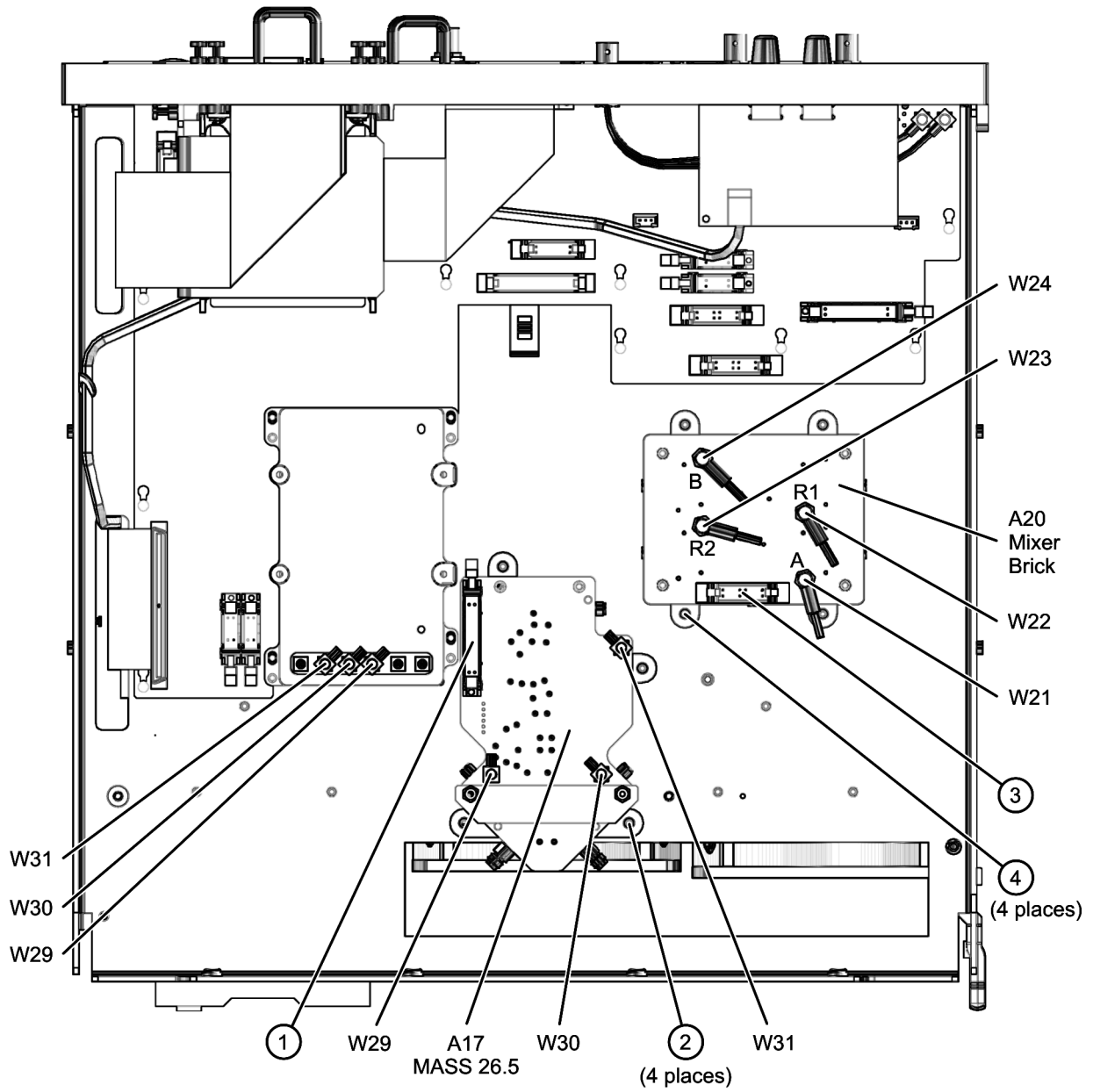

n5230\_010\_07

## Step 7. Install the 50 GHz Components

Refer to [Figure 10](#) for this procedure. New parts are listed in [Table 1 on page 5](#).

### Install the A18 MA 26.5

1. Loosely install three new screws (item ①) into the back of the MA 26.5.
2. Place the MA 26.5 in position as shown aligning the screws in the three keyholes in the test set deck side frame. Once properly aligned, tighten the screws.
3. Connect the new ribbon cable between the A18 MA 26.5 at A18J1 and the A16 test set motherboard at A16J7 (MA 26).

### Install the A19 MASS 50

1. Place the MASS 50 in position as shown.
2. Use the four screws (item ②) that were removed from the A17 MASS 26.5 to loosely install the A19 MASS 50. Leave these screw loose; they will be tightened later.
3. Connect the ribbon cable and the flexible coaxial cables (previously disconnected from the A17 MASS 26.5) to the A19 MASS 50.

### Install the A20 50 GHz Mixer Brick

1. Install the 4-dB pad on the LO input of the 50 GHz mixer brick as shown.
2. Place the 50 GHz mixer brick in position as shown.
3. Secure the mixer brick to the test set deck using the four screws (item ③) that were removed from the 20 GHz mixer brick.
4. Connect the ribbon cable and the four flexible coaxial cables (previously disconnected from the 20 GHz mixer brick) to the 50 GHz mixer brick.

### Install the A21 and A22 Test Port Couplers and the Front-Panel LED Board

1. Adhere a rubber bumper to each new 50 GHz coupler as shown below.

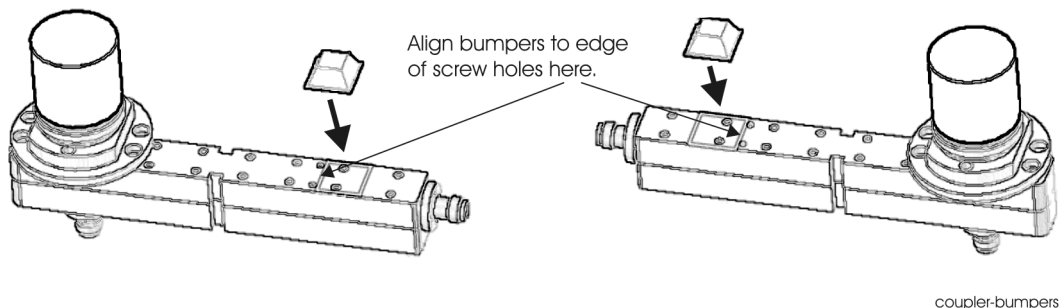

2. Install the LED board removed from the old test set deck front panel onto the new front panel using the three screws (item ④) removed from the old front panel.
3. Install the 50 GHz couplers in the new test set deck front panel and secure them with the flange nuts (item ⑤) removed from the 20 GHz couplers.
4. Set the new test set deck front panel aside for installation later.

**Figure 10 50 GHz Components Installation**

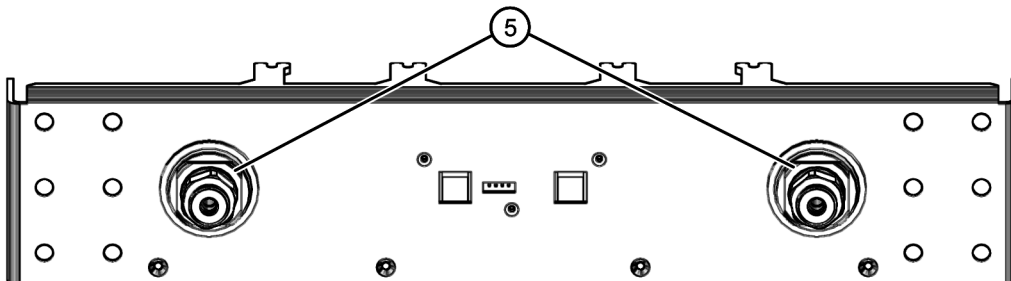
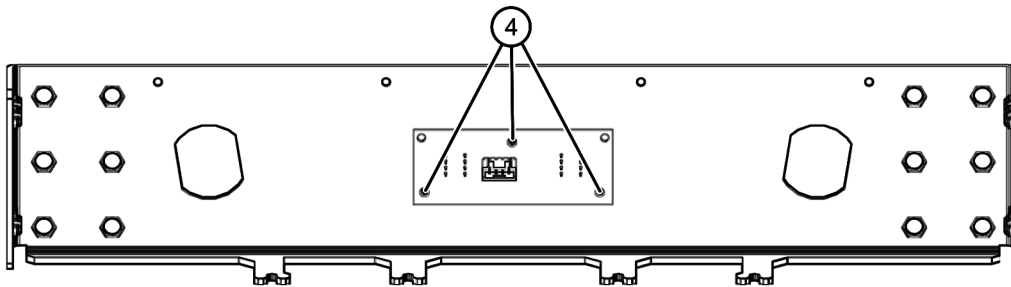
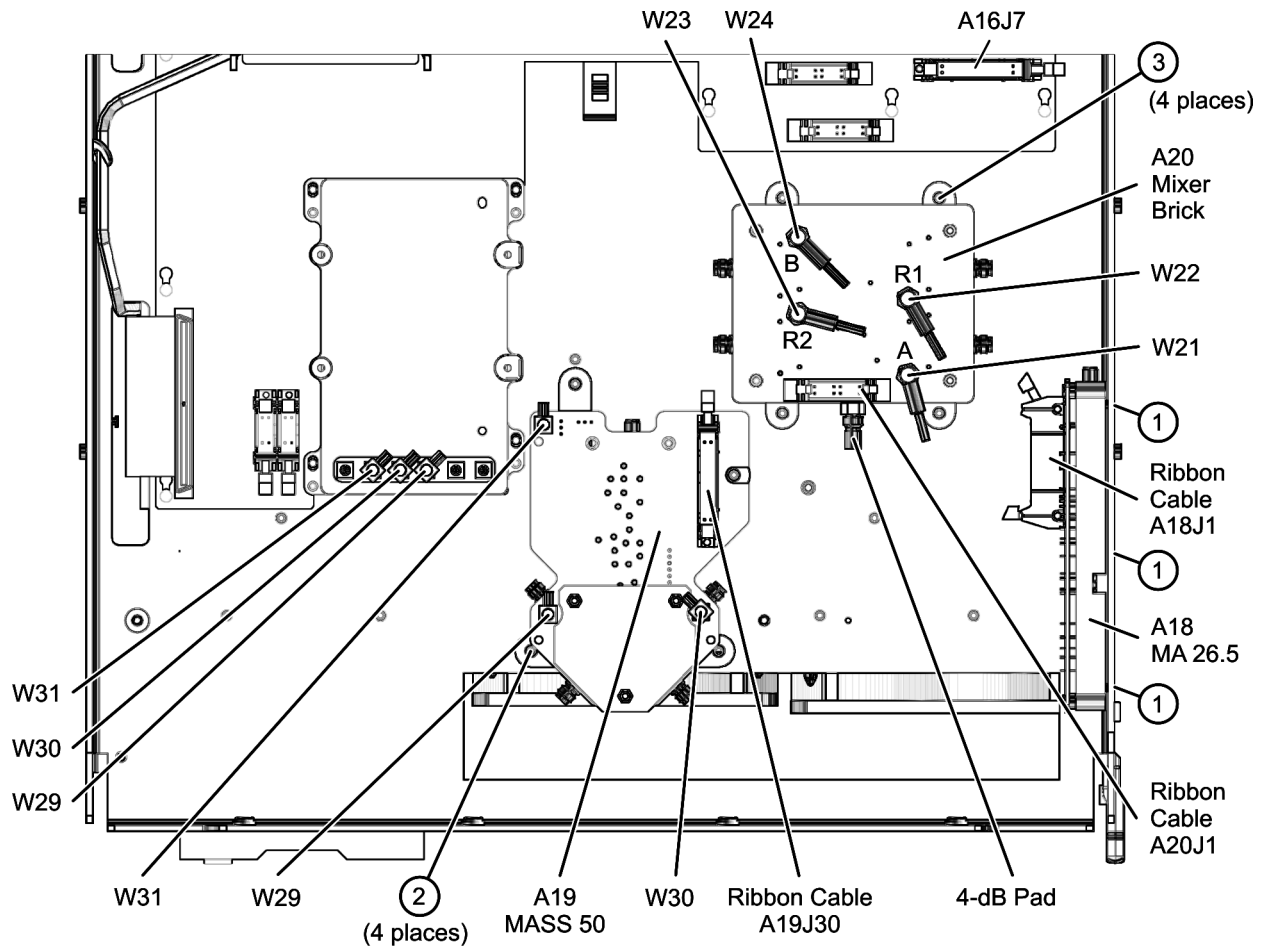

n5230\_010\_08

## Step 8. Install the 50 GHz Top to Bottom Cables

1. Place the analyzer on its side as shown in [Figure 11](#). New parts are listed in [Table 1](#) on [page 5](#).
2. Insert cables W3 and W6 into the analyzer in the direction indicated by the arrows. It may be necessary to guide the other end of the cables, on the top side of the analyzer, as they are being inserted.
3. Loosely connect cables W3 and W6 at the locations shown in [Figure 11](#) and [Figure 12](#). Once all connectors are loosely connected, tighten the connectors.

**Figure 11 50 GHz Top to Bottom Cables Installation, Bottom**

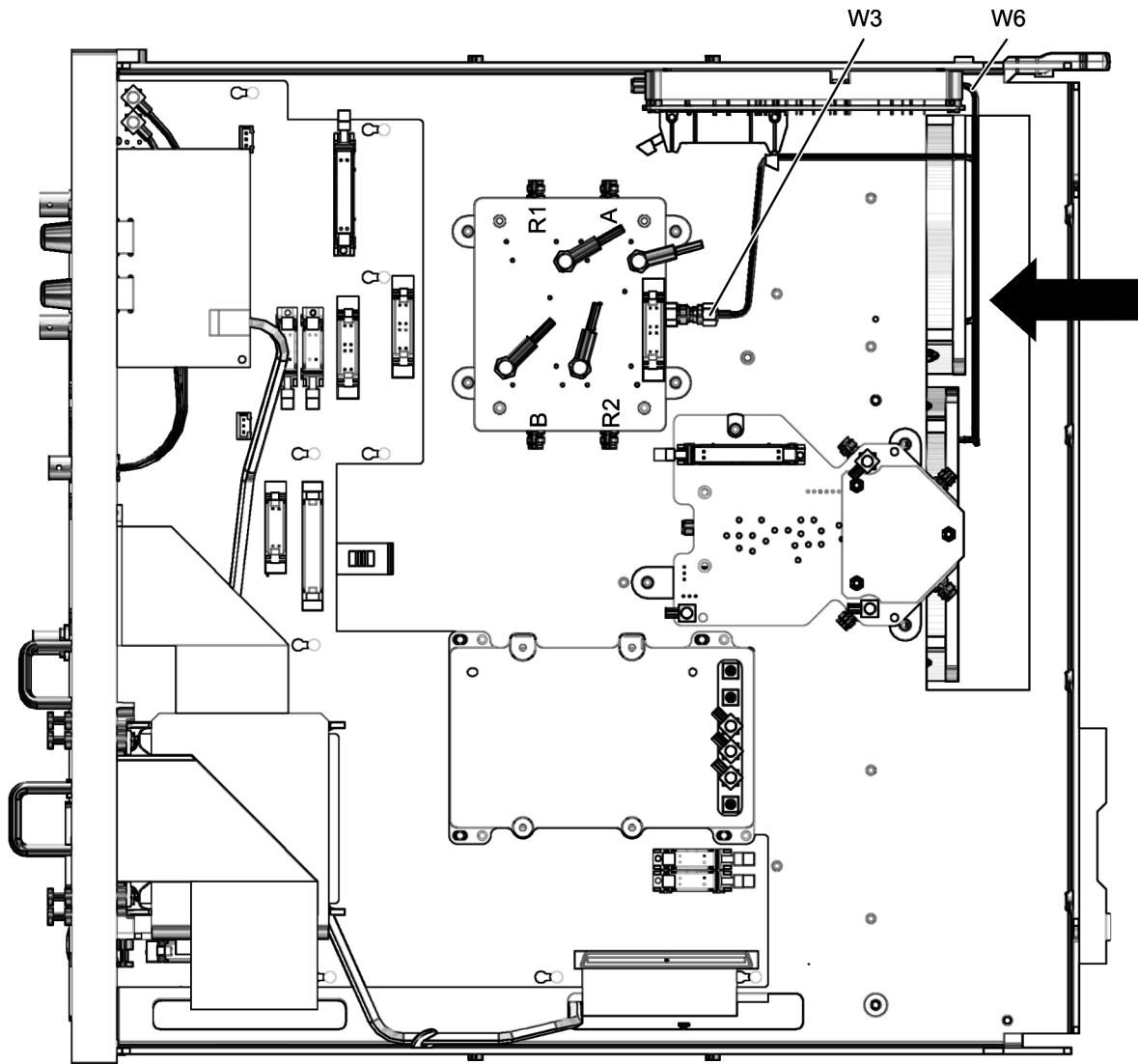

n5230\_010\_09

Figure 12 50 GHz Top to Bottom Cables Installation, Top

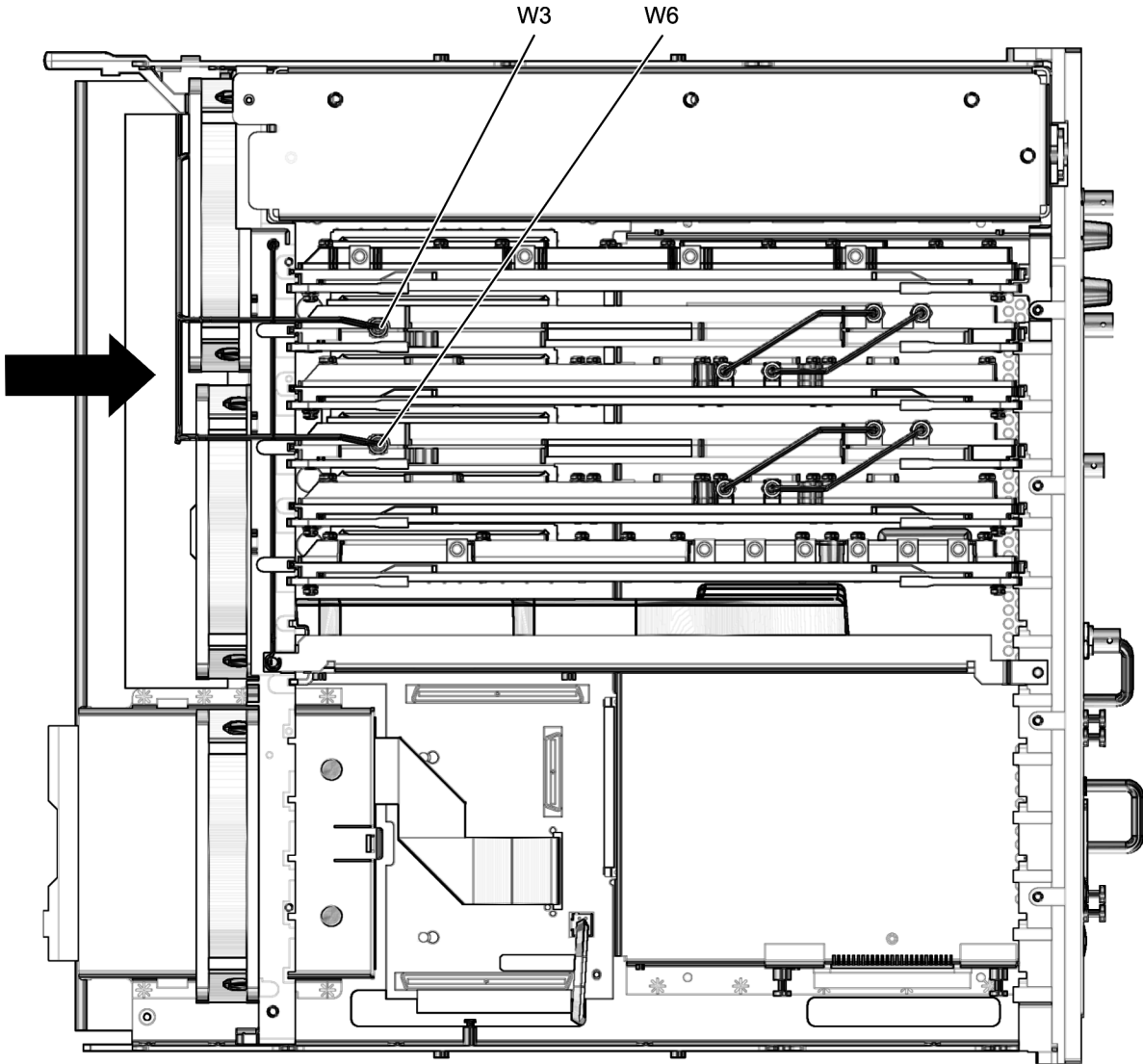

n5230\_010\_10

## Step 9. Install the New Test Set Deck Front Panel

Refer to [Figure 13](#) for this procedure. New parts are listed in [Table 1](#) on page 5.

1. Place the new test set deck front panel, with the LED board and both new couplers attached, onto the test set deck as shown.
2. Using a T-10 TORX driver, *loosely* reinstall the eight screws (items **1** through **8**) to secure the front panel to the test set deck. Once all screws have been loosely installed, torque each of the eight screws to 9 in-lbs in the order indicated (**1** through **8**). This is important to ensure proper alignment.
3. Reconnect the wrapped wire cable (item **1**) to the front-panel LED board.

**Figure 13 Test Set Deck Front Panel Installation**

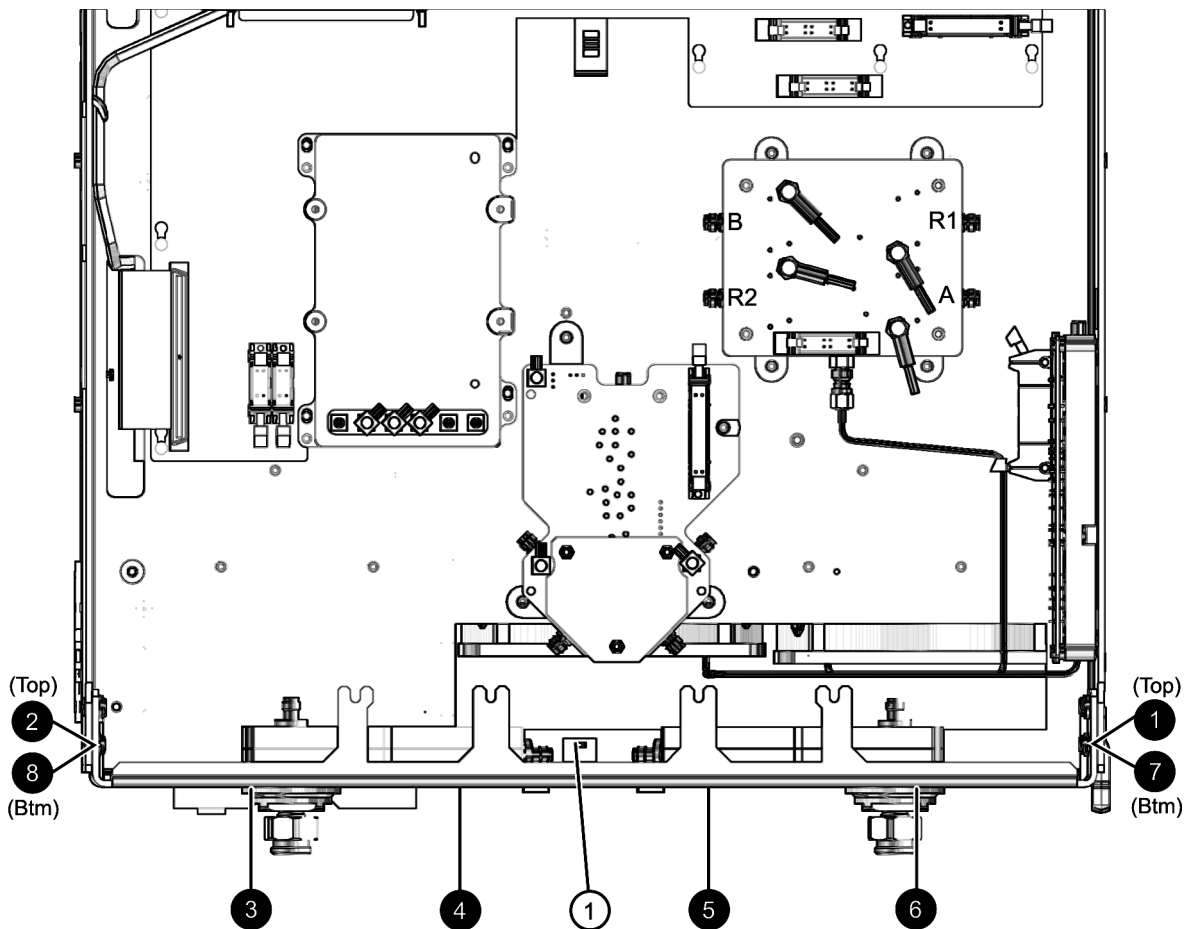

n5230\_010\_11

## Step 10. Install the 50 GHz Bottom Cables

Refer to [Figure 14](#) for this procedure. New parts are listed in [Table 1 on page 5](#).

### 1. Install cables W11 and W13:

- W11 A19 MASS 50 to A20 mixer brick (R2)
  - W13 A22 test port 2 coupler to A20 mixer brick (B)
- a. Slide cables W11 and W13 between the A19 MASS 50 and the test set deck. It will be necessary to move the A19 MASS 50 slightly to allow room for the cables.
  - b. Connect cables W11 and W13 as shown. Use a 5/16-in torque wrench set to 10 in-lbs.
  - c. Tighten the four screws (item ①) to secure the A19 MASS 50.

### 2. Install the remaining cables in the order listed:

- W8 A19 MASS 50 to A21 test port 1 coupler
- W10 A19 MASS 50 to A20 mixer brick (R1)
- W12 A21 test port 1 coupler to A20 mixer brick (A)
- W9 A19 MASS 50 to A22 test port 2 coupler
- W7 A18 MA 26.5 to A19 MASS 50

**Figure 14 50 GHz Bottom Cables Installation**

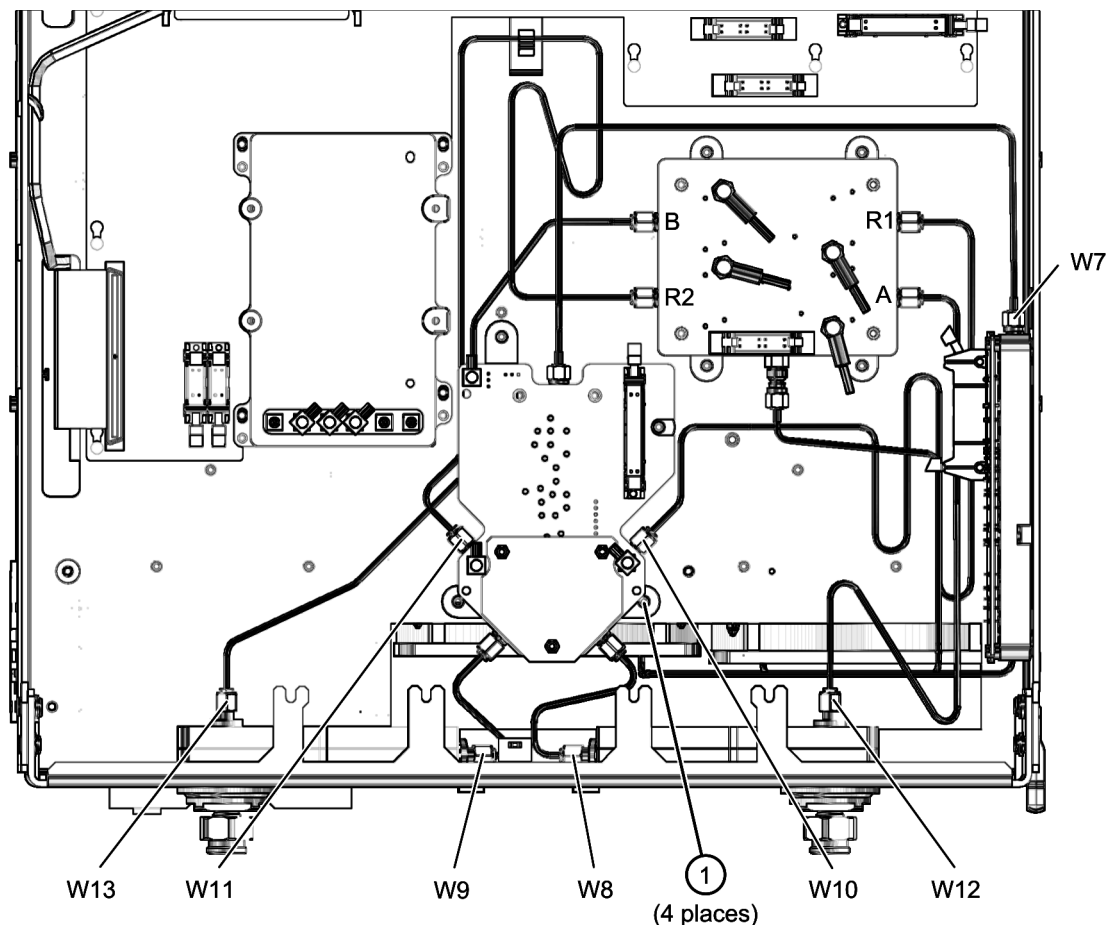

n5230\_010\_12

## Step 11. Replace the Nameplate

Refer to [Figure 15](#) for this procedure. New parts are listed in [Table 1](#) on [page 5](#).

### Remove the Old Nameplate

1. Using a sharp object such as a knife blade, lift one end of the old nameplate (item ①). Be careful not to scratch the painted surface.
2. Using your fingers, pull the nameplate completely off of the front panel and discard it.
3. If any adhesive remains on the front panel surface, it can be removed by rubbing it with your finger. Do not use a sharp object to remove this adhesive. If necessary, the surface can be cleaned with isopropyl alcohol.

### Install the New Nameplate

---

<b>IMPORTANT</b>	If the Option F50 upgrade kit will be installed to extend the frequency to 50 GHz, do not install the new nameplate provided in this upgrade kit. Instead, use the one provided in the Option F50 upgrade kit.
------------------	--

---

1. Remove the protective backing from the new nameplate to expose the adhesive. Avoid touching the adhesive with your fingers as this may affect its ability to adhere to the front panel surface.
2. *Loosely* align the new nameplate over the recess in the front panel and apply lightly.
3. Once the nameplate is properly aligned, press it firmly onto the surface to secure it.

**Figure 15 Nameplate Replacement**

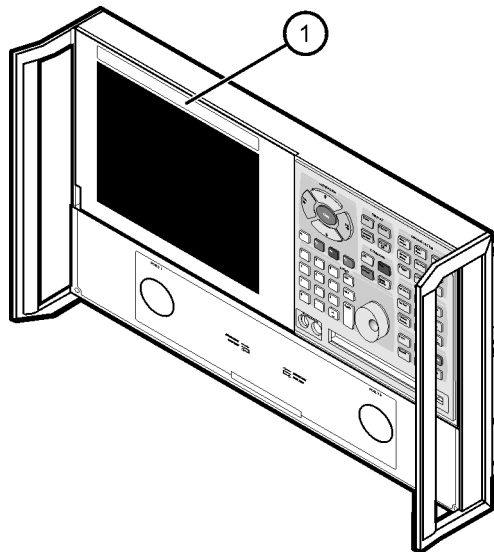

8363\_001\_01



## Step 12. Reinstall the Front Panel Assembly

**CAUTION** Before installing the front panel assembly onto the analyzer, place the analyzer right side up and lift and support the front of the analyzer chassis.

Refer to [Figure 16](#) for this procedure.

1. Reconnect the ribbon cable (item ②) to the A3 front panel interface board.
2. Slide the front panel over the test port connectors being careful to align the power switch and floppy disk drive to their corresponding front panel cutouts. Ensure that the ribbon cable (item ②) is located below the fan to prevent it from being damaged by the fan blades.
3. With a T-10 TORX driver, install the eight screws (item ①) in the sides of the frame.

**Figure 16 Front Panel Assembly Reinstallation**

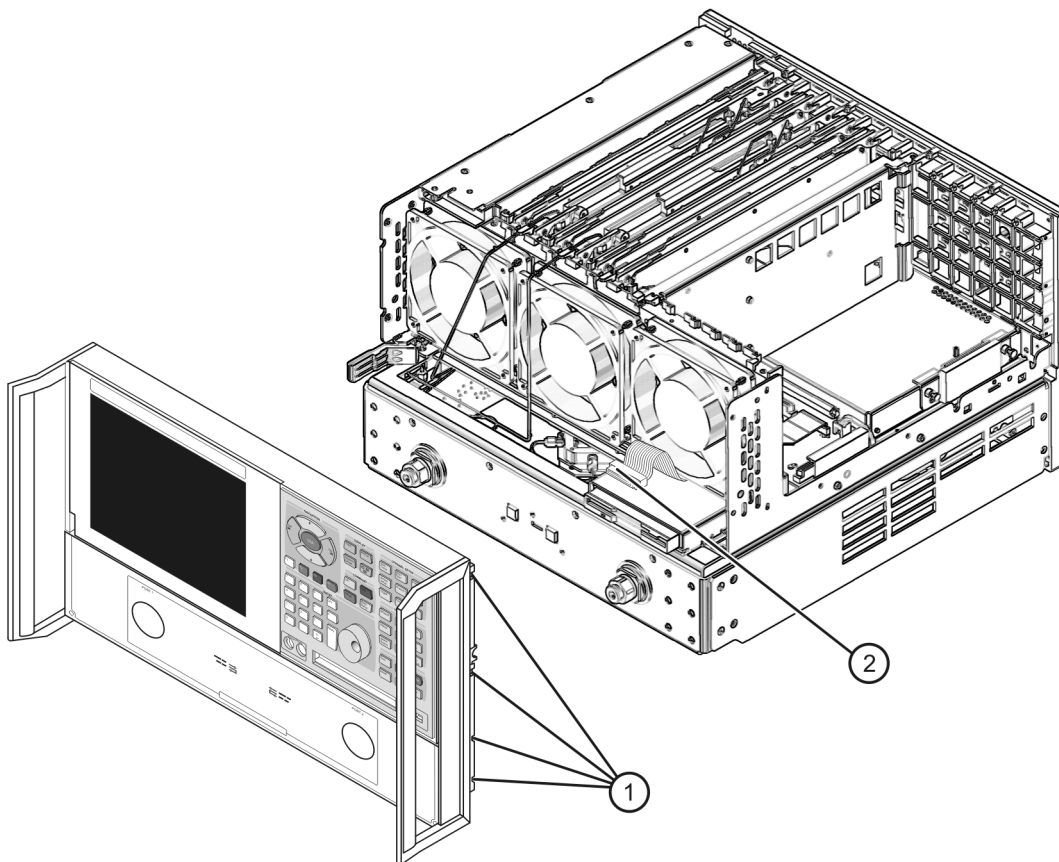

n5230\_010\_13

## Step 13. Reinstall the Inner and Outer Covers

### Reinstall the Inner Cover

1. Place the inner cover on the analyzer as shown. There are two alignment pins on the front frame that align with holes in the front of the cover to ensure proper alignment.
2. Using a T-10 TORX driver, reinstall the eleven screws (item ①).

**Figure 17 Inner Cover Reinstallation**

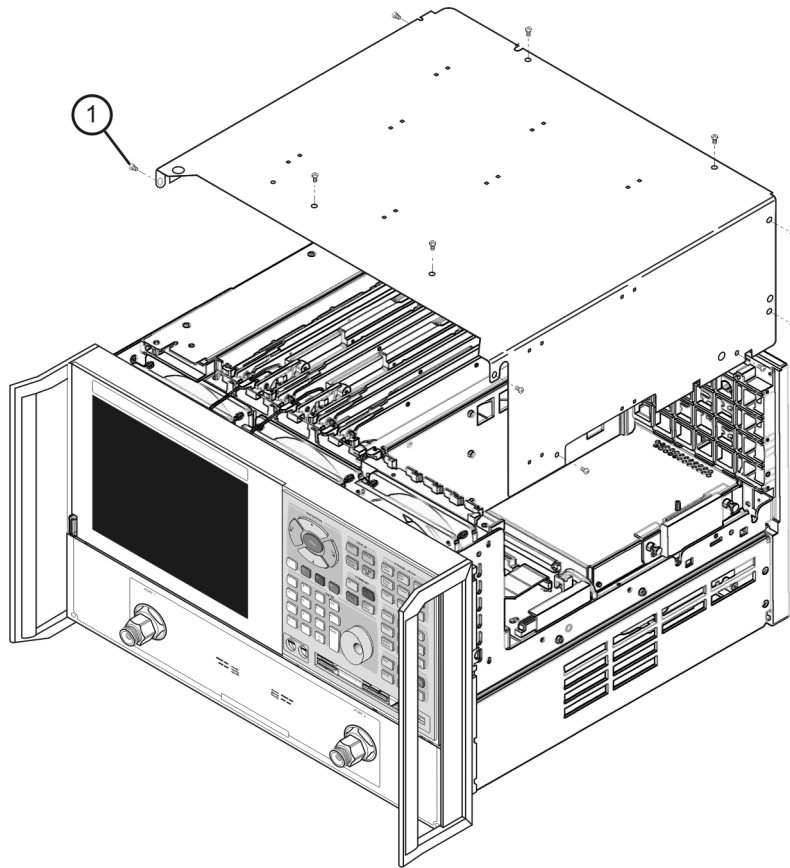

n5230\_010\_01

## Reinstall the Outer Cover

---

**CAUTION** This procedure is best performed with the analyzer resting on its front handles in the vertical position. *Do not place the analyzer on its front panel without the handles.* This will damage the front panel assemblies.

---

1. Slide the cover onto the frame.
2. Using a T-20 TORX driver, install the four rear panel feet (item ③) by installing the center screws (item ④).
3. Slide the four bottom feet (item ⑤) onto the cover.
4. Using a T-20 TORX driver, install the strap handles (item ①) by tightening the screws (item ②) on both ends.

**Figure 18 Outer Cover Reinstallation**

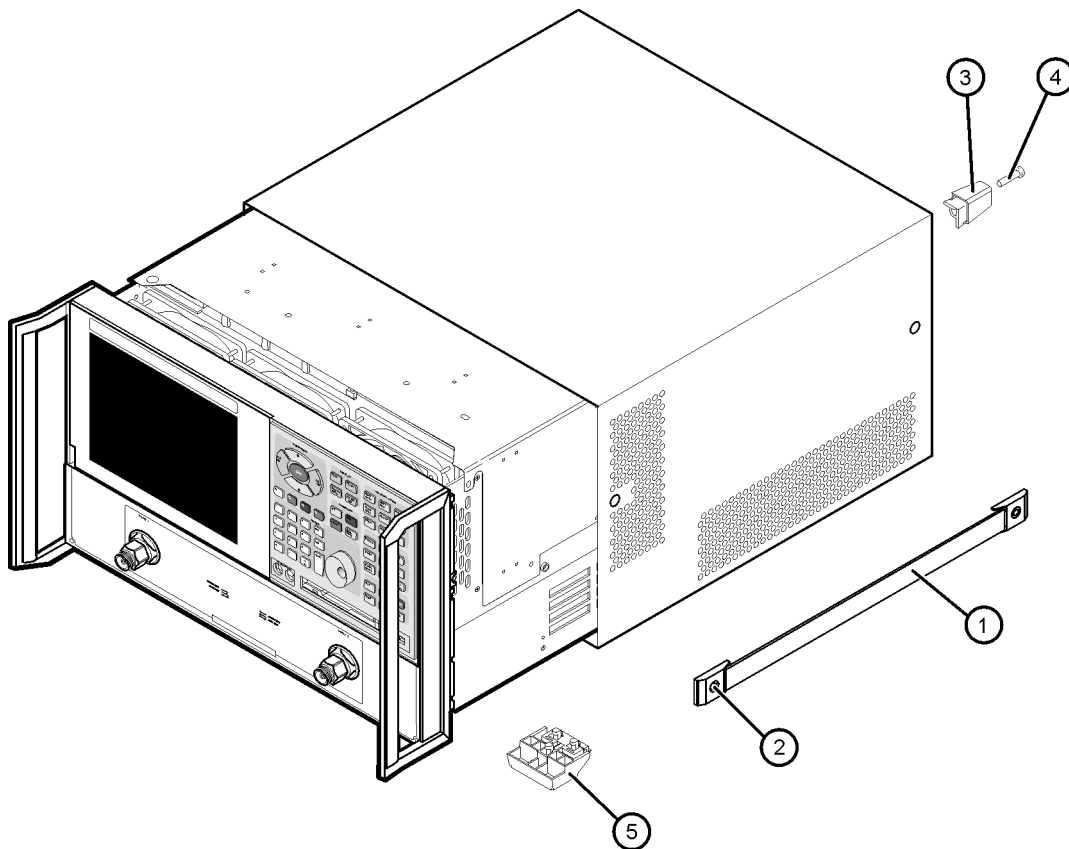

dt501a

## Step 14. Enable Option F40

### Procedure Requirements

- The analyzer must be powered up and operating to perform this procedure.
- The Network Analyzer program must be running.
- A mouse must be connected to the analyzer for this procedure.

### Option Enable Procedure

1. On the analyzer's **System** menu, point to **Service**, and then click **Option Enable**.
2. In the **Select Desired Option** list, click **F40 - 40 GHz Frequency Range**.
3. Click **Enable**.
4. Click **Yes** in answer to the displayed question in the **Restart Analyzer?** box.
5. When the installation is complete, click **Exit**.

### Option Verification Procedure

Once the analyzer has restarted and the Network Analyzer program is again running:

1. On the analyzer's Help menu, click About Network Analyzer.
2. Verify that "F40" is listed after "Options:" in the display. Click OK.

---

<b>NOTE</b>	If Option F40 has not been enabled, perform the " <a href="#">Option Enable Procedure</a> " again. If the option is still not enabled, contact Agilent Technologies. Refer to " <a href="#">Getting Assistance from Agilent</a> " on page 3.
-------------	--

---

## Step 15. Perform Post-Upgrade Adjustments

### Adjustments

The following adjustments must be made due to the hardware changes of the analyzer.

- LO power
- source calibration
- receiver calibration

These adjustments are described in the PNA service guide and in the PNA on-line HELP. A list of equipment required to perform these adjustments can be found at [“Equipment Required for Post-Upgrade Adjustments”](#) on page 7.

### Calibration

The analyzer should now operate and phase lock over its entire frequency range.

If you experience difficulty with the basic functioning of the analyzer, contact Agilent. Refer to [“Getting Assistance from Agilent”](#) on page 3.

- Although the analyzer functions, its performance relative to its specifications has not been verified.
- It is recommended that a full instrument calibration be performed using the N2721A performance test software.
- Refer to the analyzer’s service guide for information on the performance test software.

